

DO NOT SCALE OFF DRAWING. IF IN DOUBT ASK!

WEIGHT: Kg

### PAINTING/POWDER COATING

ENGINE:- PAINTED SIGNAL RED  
 FEET & PANELS:- POWDER COATED SIGNAL RED  
 HEAT EXCHANGER:- PAINTED SIGNAL RED  
 MUFFLER:- HIGH TEMP SILVER

### OIL SUMP PLUG

IS LOCATED FLUSH WITH SUMP BOTTOM'  
 OIL MUST BE DRAINED THROUGH DIP STICK  
 HOLE. ALTERNATIVELY ENGINE TO BE PACKED  
 UP TO GAIN ACCESS TO SUMP PLUG

### COOLING WATER FLOW RATE

COOLING WATER SHOULD BE ADJUSTED SO  
 WATER TO WASTE DOES NOT EXCEED 60 DEG C  
 HIGHER FLOW RATES ARE REQUIRED AT HIGHER  
 AMBIENT TEMP. FAILURE TO PROVIDE ADEQUATE  
 FLOW RATE WILL RESULT IN ENGINE FAILURE.

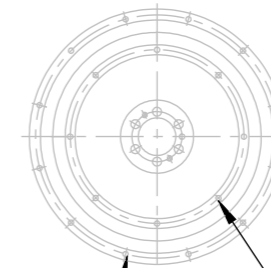
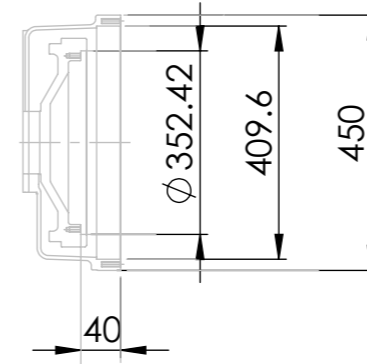

BELL HOUSING SAE 3  
 FLYWHEEL SAE 11 1/2

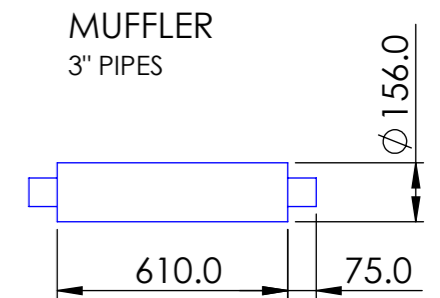
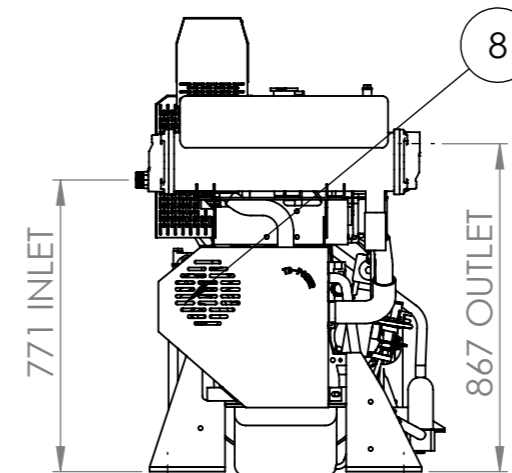
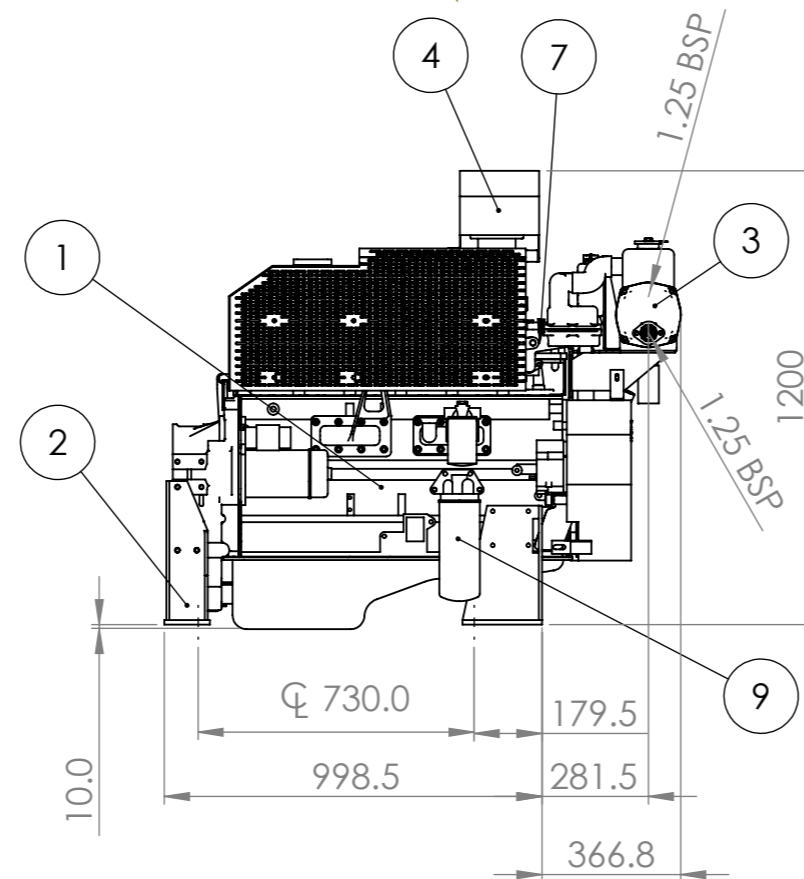
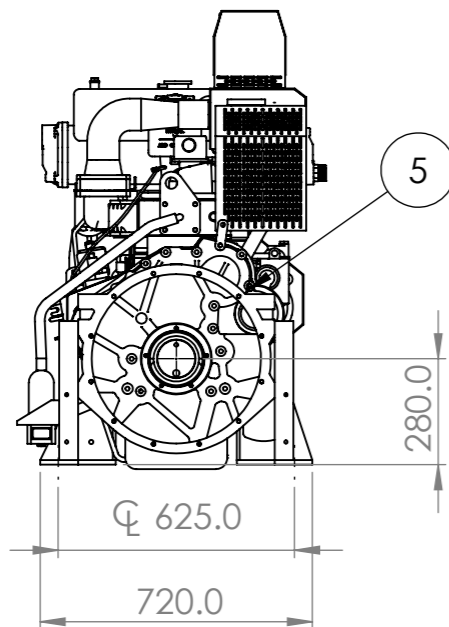
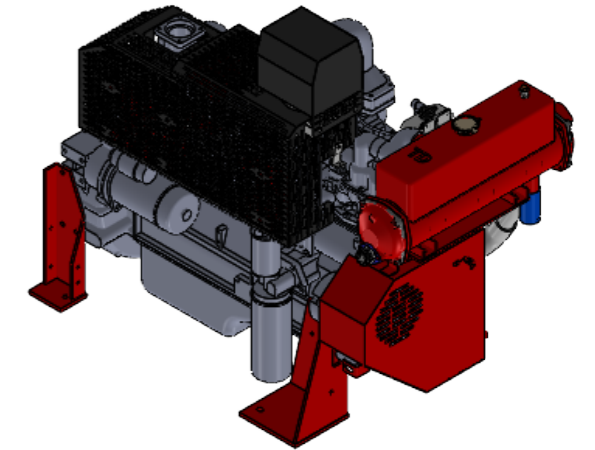
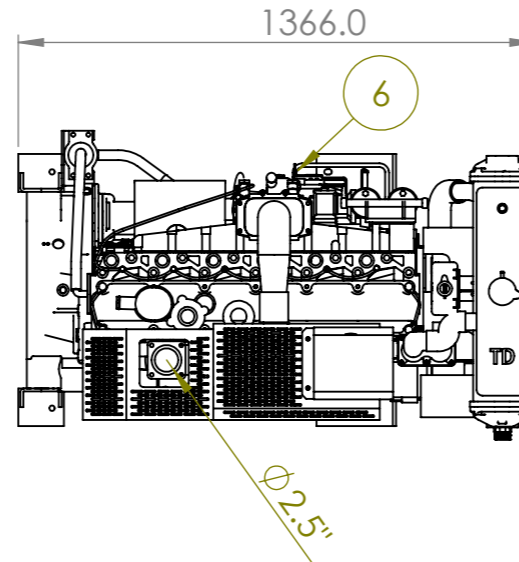

MUFFLER  
 3" PIPES

ITEM	QTY	DESCRIPTION	W&C REF No	Wt/Kg
10	1	OIL FILTER	W & C	-
9	1	FUEL FILTER	W & C	-
8	1	OIL PRESSURE SENDER	W & C	-
7	1	TEMP SENDER	W & C	-
6	1	FUEL SOLENOID	W & C	-
5	1	MAGNETIC SPEED PICK UP	W & C	-
4	1	AIR CLEANER	W & C	-
3	1	HEAT EXCHANGER	W & C	-
2	4	SUPPORT FEET	W & C	-
1	1	6110T DIESEL ENGINE	W & C	-

CAD FILE: C:\WORK SOLID WORKS\CROSSLEY 6110T-HX\6110T-HX

REV.	DESCRIPTION	DRN	DATE	CHK.	DATE.
-	-	-	-	-	-
B	ISSUED FOR MANUFACTURE	M H	21-05-2024	-	21-05-2024
A	ISSUED FOR APPROVAL	M H	21-05-2024	-	21-05-2024

TO BE MODIFIED ON SW ONLY  
 DRAWN SCALE: 1:1  
 PLOT SCALE: 1:20@ A3  
 SURFACE FINISH:  
 TOLERANCES  
 ASSEMBLY DIMENSIONS ± 3 mm  
 FABRICATED DIMENSIONS ± 2 mm  
 MACHINING DIMENSIONS ± 0.125 mm  
 UNLESS OTHERWISE SPECIFIED  
 MATERIAL:  
 - MILD STEEL SHEET

**W&C**  
**WELLING & CROSSLEY PTY LTD**  
 59 EXPORT DRIVE, BROOKLYN VIC 3012  
 1042 CANLEY VALE RD, WETHERILL PK NSW 2164  
 UNIT 5/235 CAMBOON RD, MALAGA WA 6090  
 UNIT 2/255 CHRISTENSEN RD, STAPYLTON QLD 4207  
 EMAIL: sales@wellcross.com.au

THIS DRAWING AND DESIGN REMAIN THE PROPERTY OF  
 WELLING & CROSSLEY PTY. LTD. A.B.N. 61 005 690 273.  
 THIS DRAWING AND DESIGN CAN NOT BE COPIED OR  
 ALTERED IN ANY WAY WITHOUT PRIOR WRITTEN APPROVAL  
 FROM WELLING & CROSSLEY PTY. LTD.  
 THIS DRAWING AND ALL COPIES, HARD & SOFT MUST BE  
 RETURNED TO WELLING & CROSSLEY PTY. LTD. UPON  
 REQUEST FROM WELLING & CROSSLEY PTY. LTD.

TITLE: FIRE PUMP DIESEL ENGINE  
 6110T CROSSLEY HEAT EXCHANGER  
 GENERAL ARRANGEMENT  
 DRG No: CROSSLEY 6110T-HX  
 SHEET 1 OF 1  
 A3 REV B