

DO NOT SCALE OFF DRAWING. IF IN DOUBT ASK!

- NOTES:
1. REMOVE ALL BURRS, SHARP EDGES AND WELD SPLATTER
 2. ALL FLANGES TO BE FLAT, SQUARE AND PARALLEL

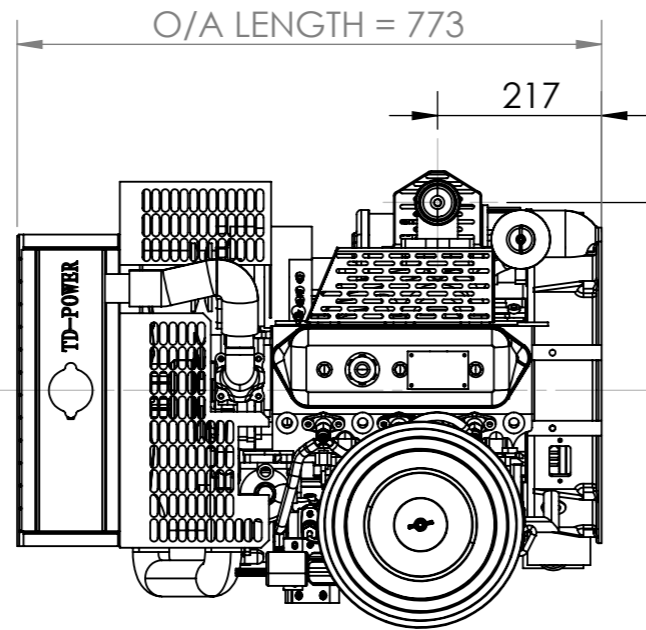

HOUSING:- SAE 4
FLYWHEEL:- SAE 7 1/2

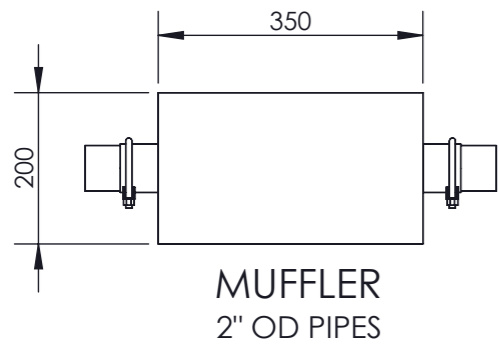
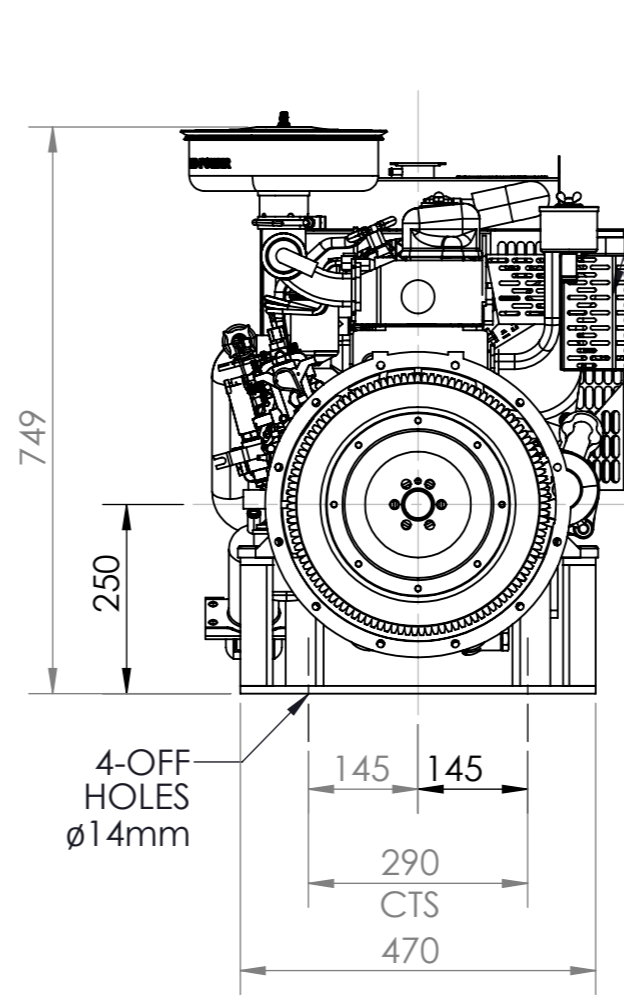
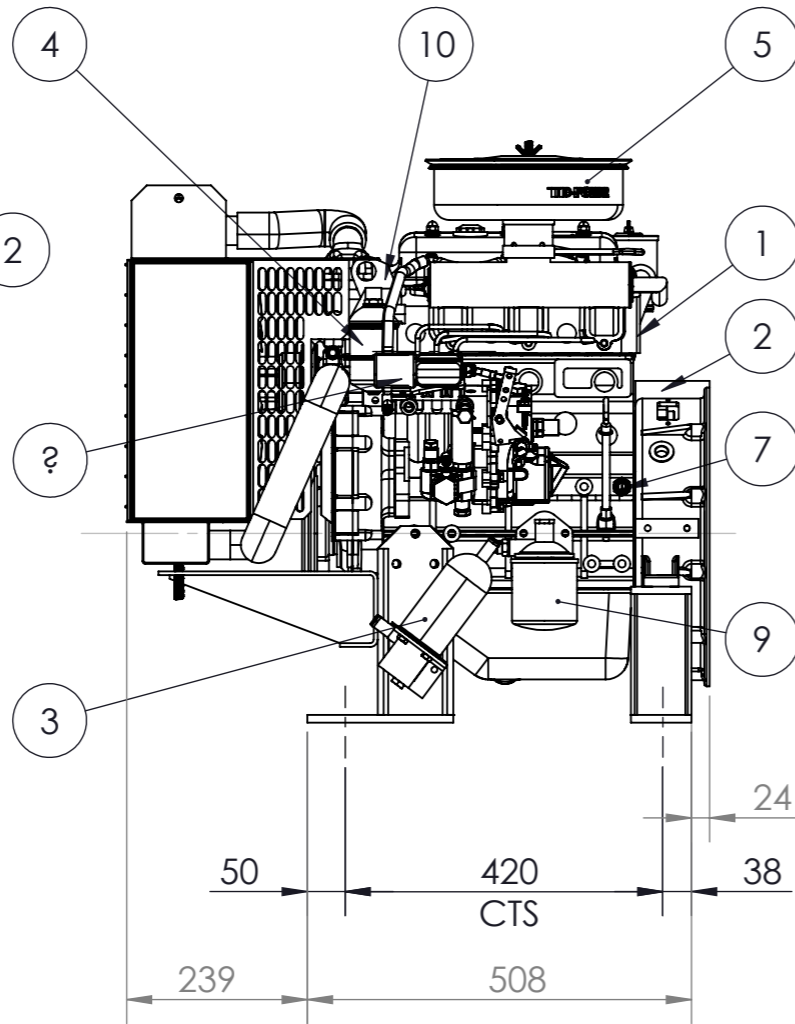
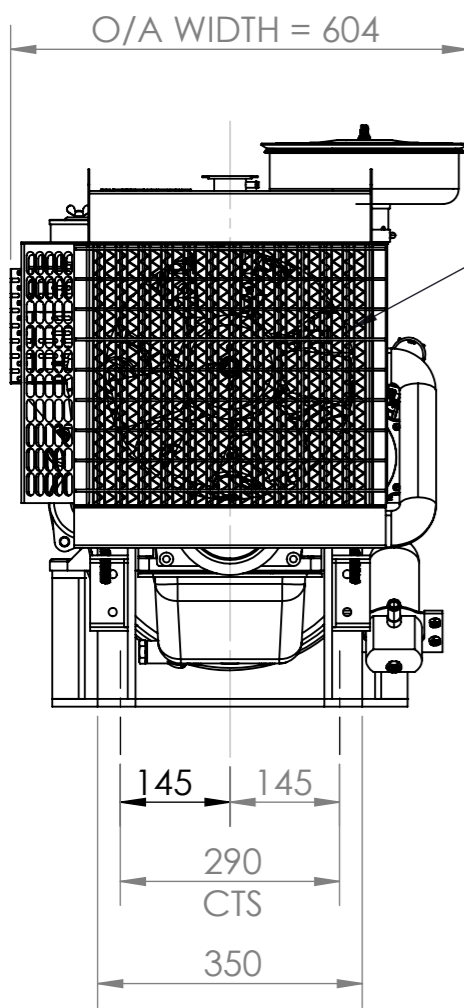
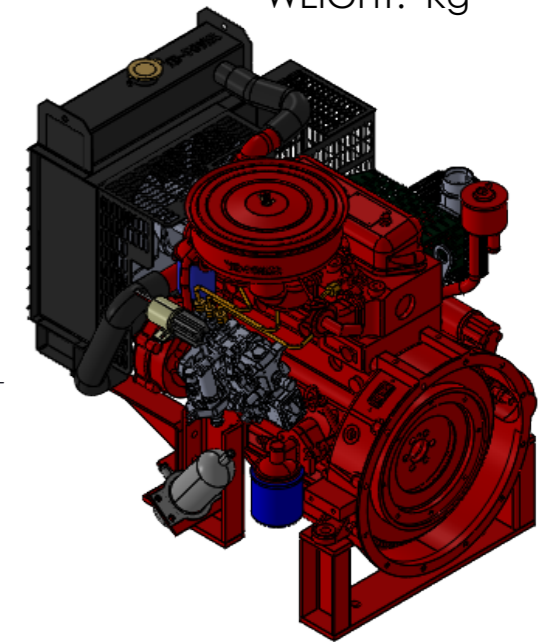
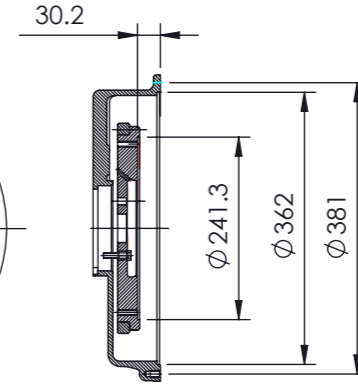
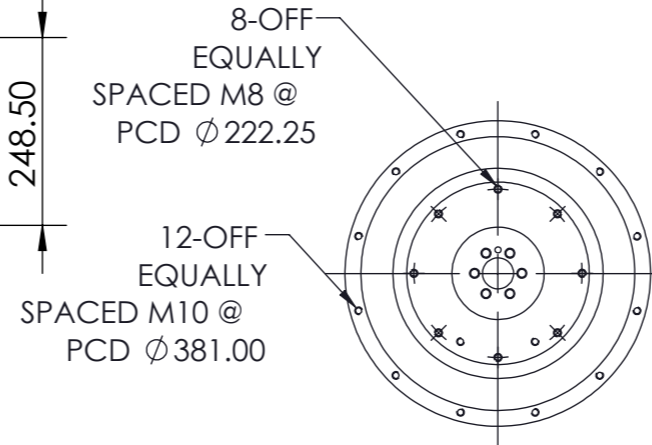

PAINTING / POWDERCOATING
ENGINE:- PAINTED SIGNAL RED
FEET & SUPPORTS:- POWDER COATED SIGNAL RED
RADIATOR:- PAINTED BLACK
MUFFLER:- HIGH TEMP SILVER

ITEM NO.	DESCRIPTION	QTY.
1	380 DIESEL ENGINE	1
2	RADIATOR	1
3	JACKET HEATER	1
4	FUEL FILTER	1
5	AIR CLEANER	1
6	MAGNETIC PICKUP	1
7	OIL PRESSURE SENDER	1
8	FUEL SOLENOID	1
9	OIL FILTER	1
10	TEMP SENDER	1
11	WATER TRAP	1

REV.	DESCRIPTION	DRN	DATE	CHK.	DATE	TOLERANCES
-	-	-	-	-	-	TO BE MODIFIED ON SW ONLY
D	DRAWING REVISED TO LATEST ASSEMBLY	P.N.L.	04/12/2020	T.L.	04/12/2020	DRAWN SCALE: 1:1
C	REVISED ENGINE DRAWING	R.M.	27/11/2013	P.N.L.	27/11/2013	PLOT SCALE: 1:10 @ A3
B	ISSUED FOR MANUFACTURE	P.N.L.	08/11/2013	T.L.	08/11/2013	SURFACE FINISH: PAINTED
A	ISSUED FOR APPROVAL	P.N.L.	08/11/2013	T.L.	08/11/2013	MATERIAL: - MILD STEEL SHEET

W&C
WELLING & CROSSLEY PTY LTD
59 EXPORT DRIVE, BROOKLYN VIC 3012
1042 CANLEY VALE RD, WETHERILL PK NSW 2164
UNIT 5/235 CAMBOON RD, MALAGA WA 6090
UNIT 2/255 CHRISTENSEN RD, STAPYLTON QLD 4207
EMAIL: sales@wellcross.com.au

THIS DRAWING AND DESIGN REMAIN THE PROPERTY OF WELLING & CROSSLEY PTY. LTD. A.B.N. 61 005 690 273. THIS DRAWING AND DESIGN CAN NOT BE COPIED OR ALTERED IN ANY WAY WITHOUT PRIOR WRITTEN APPROVAL FROM WELLING & CROSSLEY PTY. LTD.
THIS DRAWING AND ALL COPIES, HARD & SOFT MUST BE RETURNED TO WELLING & CROSSLEY PTY. LTD. UPON REQUEST FROM WELLING & CROSSLEY PTY. LTD.

TITLE: FIRE PUMP DIESEL ENGINE
380 CROSSLEY RADIATOR
GENERAL ARRANGEMENT
DRG No: 20-380RAD-007
SHEET 1 OF 1
A3 REV D

CAD FILE: F:\Users\Engineering\MECHANICAL DEPT\SUPPLIER DRGS\MOTORS\CROSSLEY\solidworks\380 RAD\20-380RAD-007