

PAINTING/POWDERCOATING

ENGINE: - PAINTED SIGNAL RED
 FEET: - POWDER COATED SIGNAL RED
 RADIATOR: - POWDER COATED SEMI-GLOSS BLACK

OIL SUMP PLUG

IS LOCATED FLUSH WITH SUMP BOTTOM. LUBE OIL MUST BE DRAINED THROUGH DIPSTICK HOLE. ALTERNATELY, DRAIN TO BE EXTENDED BY PUMP PACKAGER.

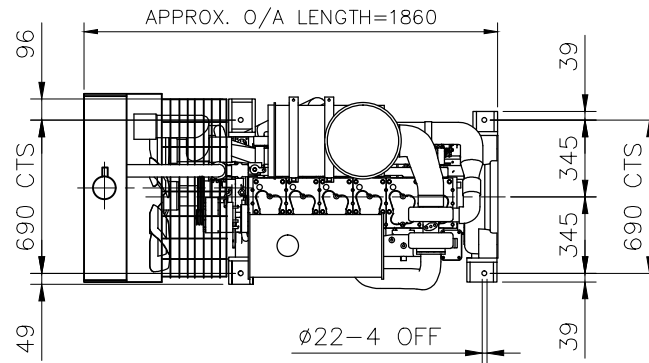

**BELL HOUSING SAE 1
 FLYWHEEL SAE 14**

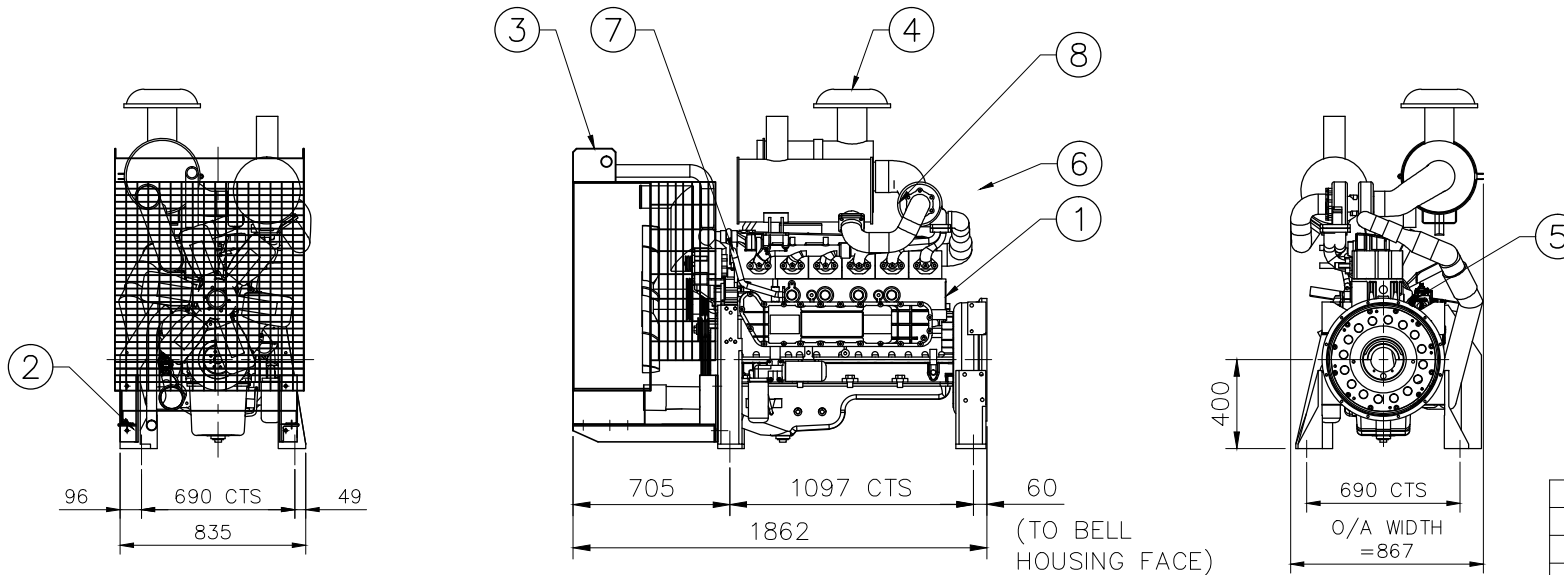
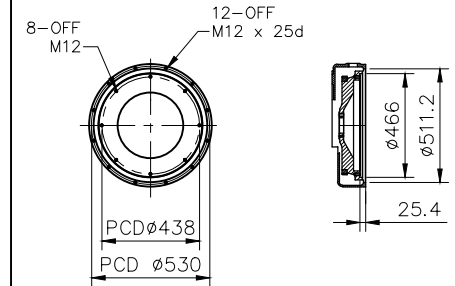

8	1	OIL PRESSURE SENDER	VDO	-
7	1	TEMP SENDER	VDO	-
6	1	FUEL SOLENOID	W&C	-
5	1	MAGNETIC SPEED PICKUP	W&C	-
4	1	AIR CLEANER	W&C	-
3	1	RADIATOR	W&C	-
2	4	SUPPORT FEET	W&C	-
1	1	6126T DIESEL ENGINE	CROSSLEY	-
ITEM	QTY	DESCRIPTION	W&C REF. No.	Wt. Kg.

-	-	-	-	-	TO BE MODIFIED ON CAD ONLY	DRN.	P.N.L.	19.02.20
-	-	-	-	-	SCALE :1:20	CHK.	D.T.	19.02.20
-	-	-	-	-	PLOT SCALE :1:20 @ A3	ENG.	R.D.	19.02.20
B	ISSUED FOR MANUFACTURE	P.N.L.	19.02.20	D.T.	19.02.20	APP.	T.L.	19.02.20
A	ISSUED FOR APPROVAL.	P.N.L.	19.02.20	D.T.	19.02.20			
REV.	DESCRIPTION	DRN	DATE	CHK.	DATE.			

W&C
WELLING & CROSSLEY PTY LTD
 59 EXPORT DRIVE BROOKLYN VIC. 3012
 UNIT 2/1040 WETHERILL PK NSW 2164
 UNIT 5/235 CAMBOON RD MALAGA WA 6090
 UNIT 11/1909 IPSWICH ROCKLEA QLD 4106
 EMAIL: wellcross@wellcross.com.au

THIS DRAWING AND DESIGN REMAIN THE PROPERTY OF WELLING & CROSSLEY PTY. LTD. A.B.N. 61 005 690 273. THIS DRAWING AND DESIGN CAN NOT BE COPIED OR ALTERED IN ANY WAY WITHOUT PRIOR WRITTEN APPROVAL FROM WELLING & CROSSLEY PTY. LTD. THIS DRAWING AND ALL COPIES, HARD & SOFT MUST BE RETURNED TO WELLING & CROSSLEY PTY. LTD. UPON REQUEST FROM WELLING & CROSSLEY PTY. LTD.

TITLE : FIRE PUMP DIESEL ENGINE
 6126T CROSSLEY RADIATOR
 GENERAL ARRANGEMENT

DRG No: 20-6126T-007

REV B