

### ELECTRICAL SYSTEM

24 VOLT NEGATIVE EARTH  
 COLD CRANKING AMPS 500  
 FLYWHEEL TEETH 152  
 VDO OIL & TEMP SENDERS  
 ARE FITTED  
 OIL PRESSURE 1000Kpa  
 WATER TEMP 120°C

### OIL SUMP PLUG

IS LOCATED FLUSH WITH  
 SUMP BOTTOM.  
 LUBE OIL MUST BE DRAINED  
 THROUGH DIPSTICK HOLE  
 ALTERNATELY DRAIN TO BE  
 EXTENDED BY PUMP PACKAGER

BELL HOUSING SAE 3  
 FLYWHEEL SAE 11 1/2

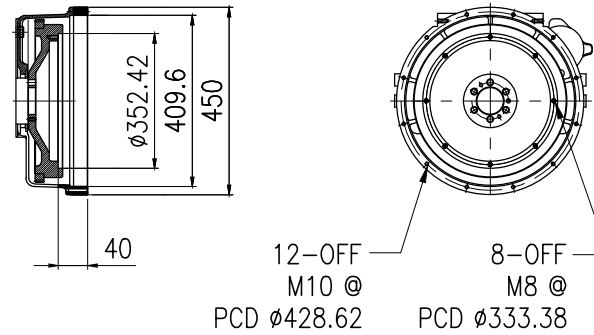

### PAINTING / POWDERCOATING

ENGINE: - PAINTED SIGNAL RED  
 FEET: - POWDER COATED  
 SIGNAL RED  
 RADIATOR: - POWDER COATED  
 SEMIGLOSS BLACK  
 MUFFLER: - HIGH TEMP BLACK

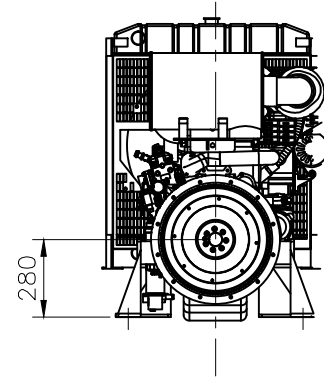
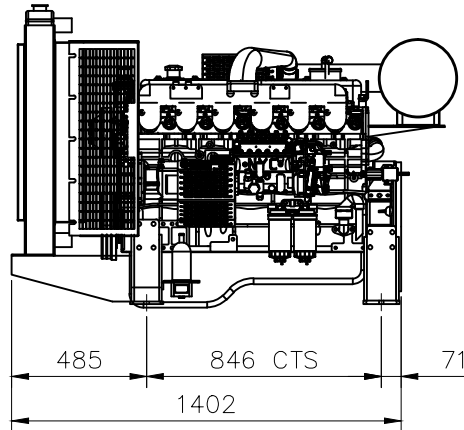
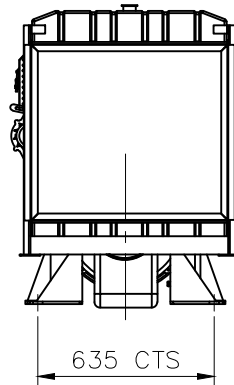
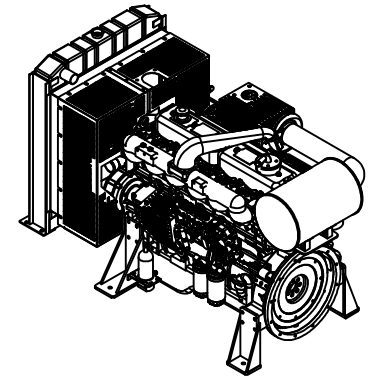
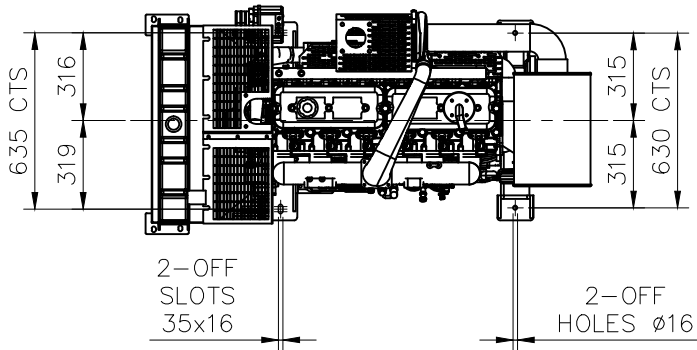
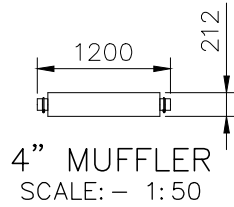

-	-	-	-	-	TO BE MODIFIED ON CAD ONLY	DRN.	P.N.L.	23.05.18	<b>W&amp;C</b>		TITLE : FIRE PUMP DIESEL ENGINE 6108T CROSSLEY RADIATOR GENERAL ARRANGEMENT
-	-	-	-	SCALE :1:20	CHK.	M.T.	23.05.18				
-	-	-	-	PLOT SCALE :1:20 @ A3	ENG.	P.N.L.	23.05.18	<b>WELLING &amp; CROSSLEY PTY LTD</b> 59 EXPORT DRIVE BROOKLYN VIC. 3012 UNIT 2/1040 WETHERILL PK NSW 2164 UNIT 5/235 CAMBOON RD MALAGA WA 6090 UNIT 11/1909 IPSWICH ROCKLEA QLD 4106 EMAIL: wellcross@wellcross.com.au			
B	ISSUED FOR MANUFACTURE	P.N.L.	23.05.18	M.T.	23.05.18	APP.	T.L.				
A	ISSUED FOR APPROVAL	P.N.L.	23.05.18	M.T.	23.05.18	TOLERANCES ASSEMBLY DIMENSIONS ± 3 mm FABRICATED DIMENSIONS ± 2 mm MACHINING DIMENSIONS ± 0.125 mm UNLESS OTHERWISE SPECIFIED		DRG No:	20-6108T-007	A3	REV B
REV.	DESCRIPTION	DRN	DATE	CHK.	DATE.						