

BELL HOUSING & FLY WHEEL DETAILS

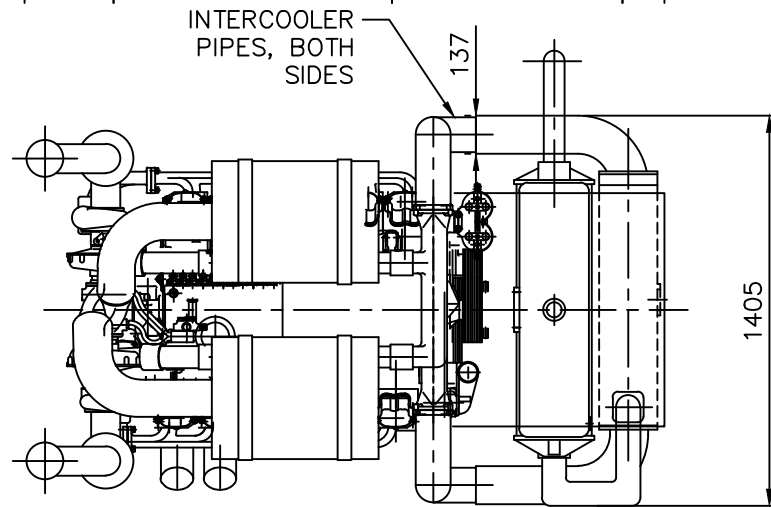

COOLING WATER FLOW  
1 Ltr / SEC  
PER 70kw OF LOAD

ITEM	QTY	DESCRIPTION	W&C REF. No.	Wt. Kg.
8	2	REAR SUPPORT FEET	-	-
7	2	FRONT SUPPORT FEET	-	-
6	1	GUARD SUPPORT	-	-
5	2	WATER TRAP	-	-
4	2	AIR FILTER	-	-
3	1	H/X 800 INTERCOOLER	204800	-
2	1	H/X PH 300 HEAT EXCHANGER	204300	-
1	1	DAEWOO V12 DIESEL 222LE	-	-

REV.	DESCRIPTION	DRN	DATE	CHK.	DATE.
-	-	-	-	-	-
-	-	-	-	-	-
-	-	-	-	-	-
B	ISSUED FOR MANUFACTURE	P.N.L.	23.08.16	R.D.	23.08.16
A	ISSUED FOR APPROVAL	P.N.L.	23.08.16	R.D.	23.08.16

TO BE MODIFIED ON CAD ONLY  
SCALE : 1:20  
PLOT SCALE : 1:20 @ A3

TOLERANCES  
FABRICATED DIMENSIONS ± 2 mm  
MACHINING DIMENSIONS ± 0.125 mm  
UNLESS OTHERWISE SPECIFIED

DRN. P.N.L. 23.08.16  
CHK. R.D. 23.08.16  
ENG. P.N.L. 23.08.16  
APP. R.D. 23.08.16

**W&C**  
WELLING & CROSSLEY PTY LTD  
50-58 NEW STREET STH KINGSVILLE VIC. 3015  
2/6-8 ALLEN PLACE WETHERILL PK NSW 2164  
5/235 CAMBORN RD MALAGA WA 6090  
11/1909 IPSWICH ROCKLEA QLD 4106  
EMAIL: wellcross@wellcross.com.au

CLIENT : -

THIS DRAWING AND DESIGN REMAIN THE PROPERTY OF WELLING & CROSSLEY PTY. LTD. A.B.N. 61 005 690 273. THIS DRAWING AND DESIGN CAN NOT BE COPIED OR ALTERED IN ANY WAY WITHOUT PRIOR WRITTEN APPROVAL FROM WELLING & CROSSLEY PTY. LTD. THIS DRAWING AND ALL COPIES, HARD & SOFT MUST BE RETURNED TO WELLING & CROSSLEY PTY. LTD. UPON REQUEST FROM WELLING & CROSSLEY PTY. LTD.

TITLE : DIESEL ENGINE - DAEWOO DP222L SERIES HEAT EXCHANGER GENERAL ARRANGEMENT

DRG No: 20-DP222L-006

A3 REV B