

COOLING WATER FLOW RATE

MINIMUM FLOW RATE IS 1 LTR PER SECOND @ 20° PER 70KW OF LOAD. HIGHER FLOW RATES ARE REQUIRED AT HIGHER TEMPERATURES. FAILURE TO PROVIDE THIS FLOW RATE WILL CAUSE PERMANENT ENGINE FAILURE WITHIN MINUTES OF RUNNING THE DIESEL ENGINE

PAINTING / POWDERCOATING

ENGINE: - PAINTED SIGNAL RED
 FEET & PANELS: - POWDER COATED SIGNAL RED
 HEAT EXCHANGER: - PAINTED SIGNAL RED

ELECTRICAL SYSTEM

24 VOLT NEGATIVE EARTH
 COLD CRANKING AMPS 315
 FLYWHEEL MAGNETIC PICK-UP
 VDO OIL & TEMP SENDERS
 ARE FITTED
 OIL PRESSURE 1000Kpa
 WATER TEMP 120°C

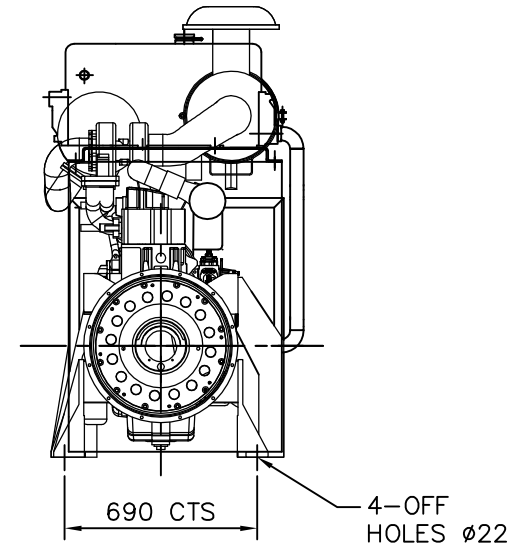
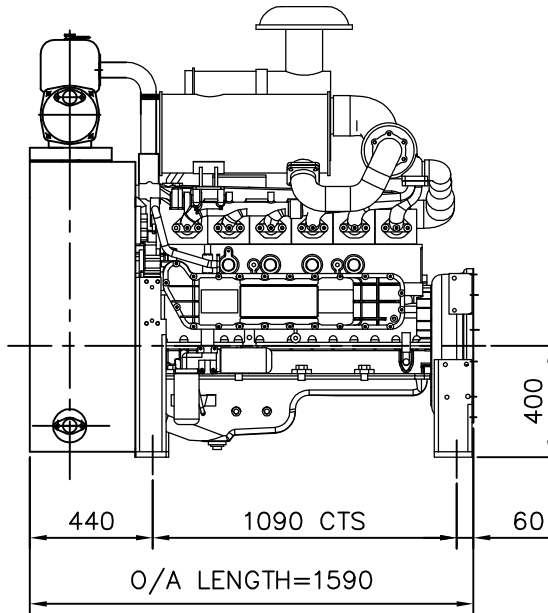
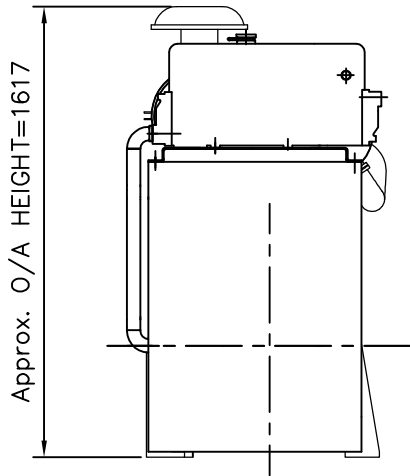
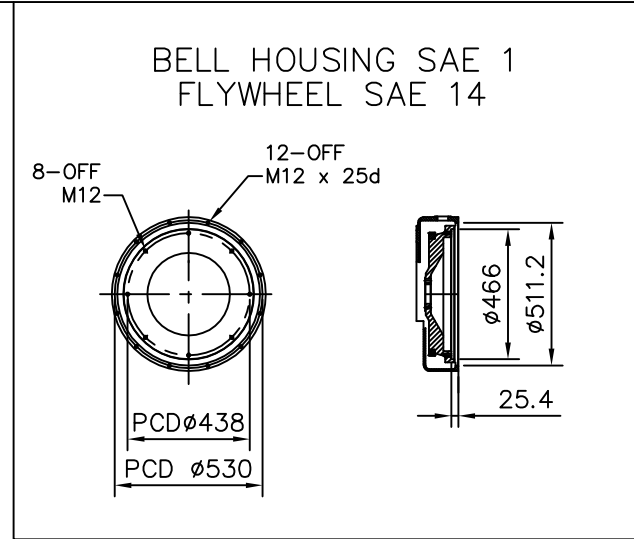
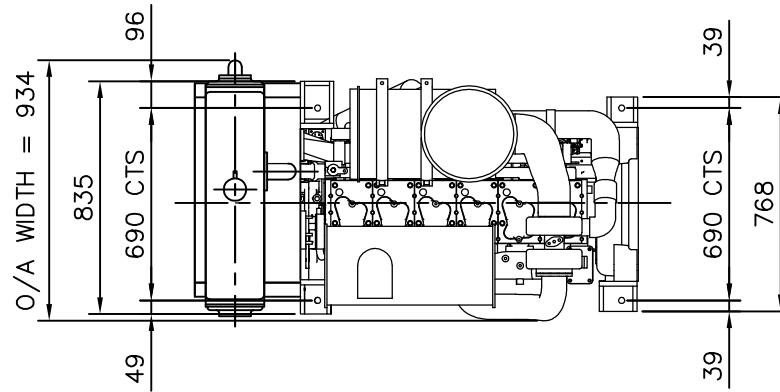

-	-	-	-	-	TO BE MODIFIED ON CAD ONLY	DRN.	R.M.	03.03.14	W&C WELLING & CROSSLEY PTY LTD 59 EXPORT DRIVE BROOKLYN VIC. 3012 UNIT 2/1040 WETHERILL PK NSW 2164 UNIT 5/235 CAMBOON RD MALAGA WA 6090 UNIT 11/1909 IPSWICH ROCKLEA QLD 4106		TITLE : FIRE ENGINE -CROSSLEY 6126Ti-2L HEAT EXCHANGER GENERAL ARRANGEMENT
-	-	-	-	SCALE : 1:20	CHK.	P.N.L.	03.03.14				
-	-	-	-	PLOT SCALE : 1:20 @ A3	ENG.	P.N.L.	03.03.14				
B	ISSUED FOR MANUFACTURE	R.M.	03.03.14	P.N.L.	03.03.14	APP.	T.L.	03.03.14			
A	ISSUED FOR APPROVAL.	R.M.	03.03.14	P.N.L.	03.03.14	TOLERANCES FABRICATED DIMENSIONS ± 2 mm MACHINING DIMENSIONS ± 0.125 mm UNLESS OTHERWISE SPECIFIED			THIS DRAWING AND DESIGN REMAIN THE PROPERTY OF WELLING & CROSSLEY PTY. LTD. A.B.N. 61 005 690 273. THIS DRAWING AND DESIGN CAN NOT BE COPIED OR ALTERED IN ANY WAY WITHOUT PRIOR WRITTEN APPROVAL FROM WELLING & CROSSLEY PTY. LTD. THIS DRAWING AND ALL COPIES, HARD & SOFT MUST BE RETURNED TO WELLING & CROSSLEY PTY. LTD. UPON REQUEST FROM WELLING & CROSSLEY PTY. LTD.	DRG No: 20-6126Ti-2L-006	REV B
REV.	DESCRIPTION	DRN	DATE	CHK.	DATE.						