

PAINTING / POWDERCOATING

ENGINE: - PAINTED SIGNAL RED
 FEET & PANELS: - POWDER COATED SIGNAL RED
 HEAT EXCHANGER: - PAINTED SIGNAL RED
 MUFFLER: - HIGH TEMP SILVER

OIL SUMP PLUG

IS LOCATED FLUSH WITH SUMP BOTTOM. LUBE OIL MUST BE DRAINED THROUGH DIPSTICK HOLE. ALTERNATELY DRAIN TO BE EXTENDED BY PUMP PACKAGER.

COOLING WATER FLOW RATE

MINIMUM FLOW RATE REQUIRED IS 0.8 LITRE PER SECOND @ 20°. HIGHER FLOW RATES ARE REQUIRED AT HIGHER TEMPERATURES. FAILURE TO PROVIDE THIS FLOW RATE WILL CAUSE PERMANENT ENGINE FAILURE WITHIN MINUTES OF RUNNING THE DIESEL ENGINE.

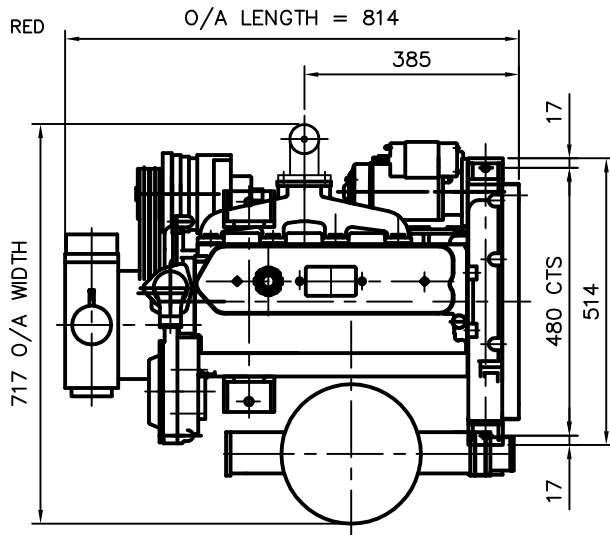

8-OFF EQUALLY SPACED
 M8 @ PCD Ø222.25

12-OFF EQUALLY SPACED
 M10 @ PCD Ø381.00

HOUSING SAE 4 & FLYWHEEL SAE 7 1/2

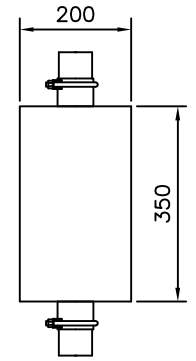
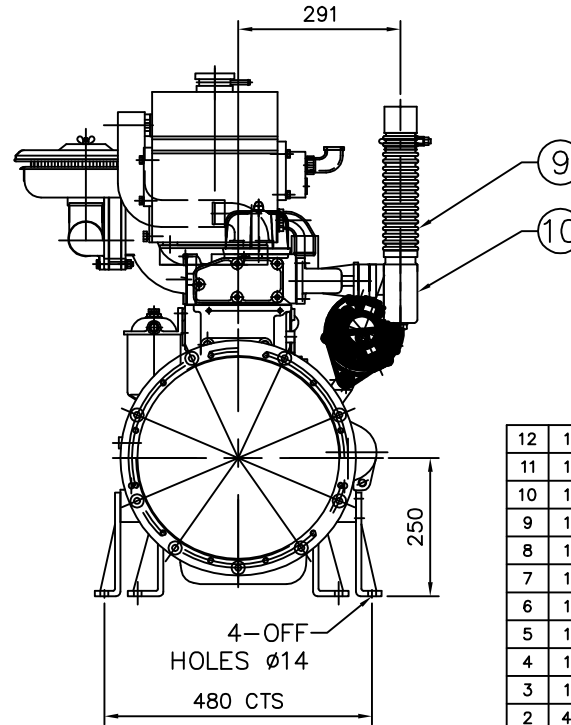
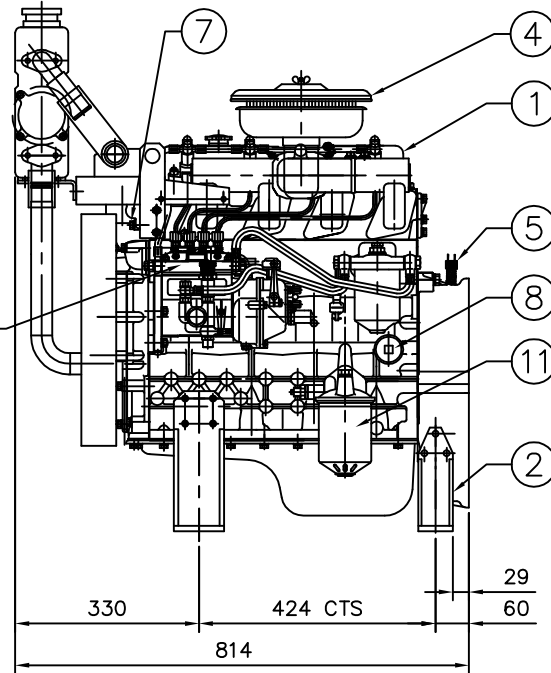
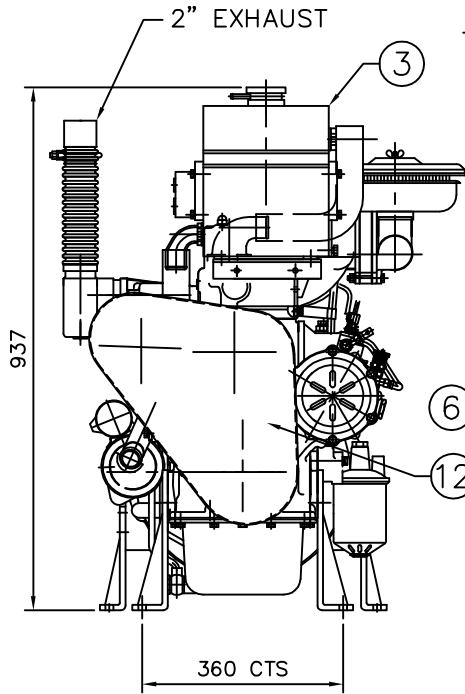
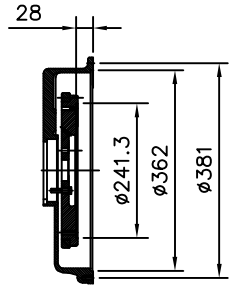

MUFFLER
 2" OD PIPES

ITEM	QTY	DESCRIPTION	W&C REF. No.	Wt. Kg.
12	1	GUARD	W&C	-
11	1	OIL FILTER	W&C	-
10	1	WATER TRAP	W&C	-
9	1	EXHAUST FLEX	W&C	-
8	1	OIL PRESSURE SENDER	VDO	-
7	1	TEMP SENDER	VDO	-
6	1	FUEL SOLENOID	W&C	-
5	1	MAGNETIC SPEED PICKUP	W&C	-
4	1	AIR CLEANER	W&C	-
3	1	HEAT EXCHANGER	CH200	-
2	4	SUPPORT FEET	W&C	-
1	1	490 DIESEL ENGINE	CROSSLEY	-

REV.	DESCRIPTION	DRN	DATE	CHK.	DATE.
-	-	-	-	-	-
D	ENGINE DRAWING REVISED	R.M.	27.11.13	P.N.L.	27.11.13
C	ENGINE DRAWING REVISED	R.M.	20.11.13	P.N.L.	20.11.13
B	ISSUED FOR MANUFACTURE	R.M.	14.11.13	P.N.L.	14.11.13
A	ISSUED FOR APPROVAL	R.M.	14.11.13	P.N.L.	14.11.13

TO BE MODIFIED ON CAD ONLY				DRN.	R.M.	14.11.13
SCALE : 1:10				CHK.	P.N.L.	14.11.13
PLOT SCALE : 1:10 @ A3				ENG.	P.N.L.	14.11.13
TOLERANCES				APP.	T.L.	14.11.13
ASSEMBLY DIMENSIONS ± 3 mm						
FABRICATED DIMENSIONS ± 2 mm						
MACHINING DIMENSIONS ± 0.125 mm						
UNLESS OTHERWISE SPECIFIED						

W&C
WELLING & CROSSLEY PTY LTD
 59 EXPORT DRIVE BROOKLYN VIC. 3012
 UNIT 2/1040 WETHERILL PK NSW 2164
 UNIT 5/235 CAMBOON RD MALAGA WA 6090
 UNIT 11/1909 IPSWICH ROCKLEA QLD 4106

THIS DRAWING AND DESIGN REMAIN THE PROPERTY OF WELLING & CROSSLEY PTY. LTD. A.B.N. 61 005 690 273. THIS DRAWING AND DESIGN CAN NOT BE COPIED OR ALTERED IN ANY WAY WITHOUT PRIOR WRITTEN APPROVAL FROM WELLING & CROSSLEY PTY. LTD. THIS DRAWING AND ALL COPIES, HARD & SOFT MUST BE RETURNED TO WELLING & CROSSLEY PTY. LTD. UPON REQUEST FROM WELLING & CROSSLEY PTY. LTD.

TITLE : FIRE PUMP DIESEL ENGINE
 490H CROSSLEY HEAT EXCHANGER
 GENERAL ARRANGEMENT
 DRG No: 20-490N-006
 A3 REV D