

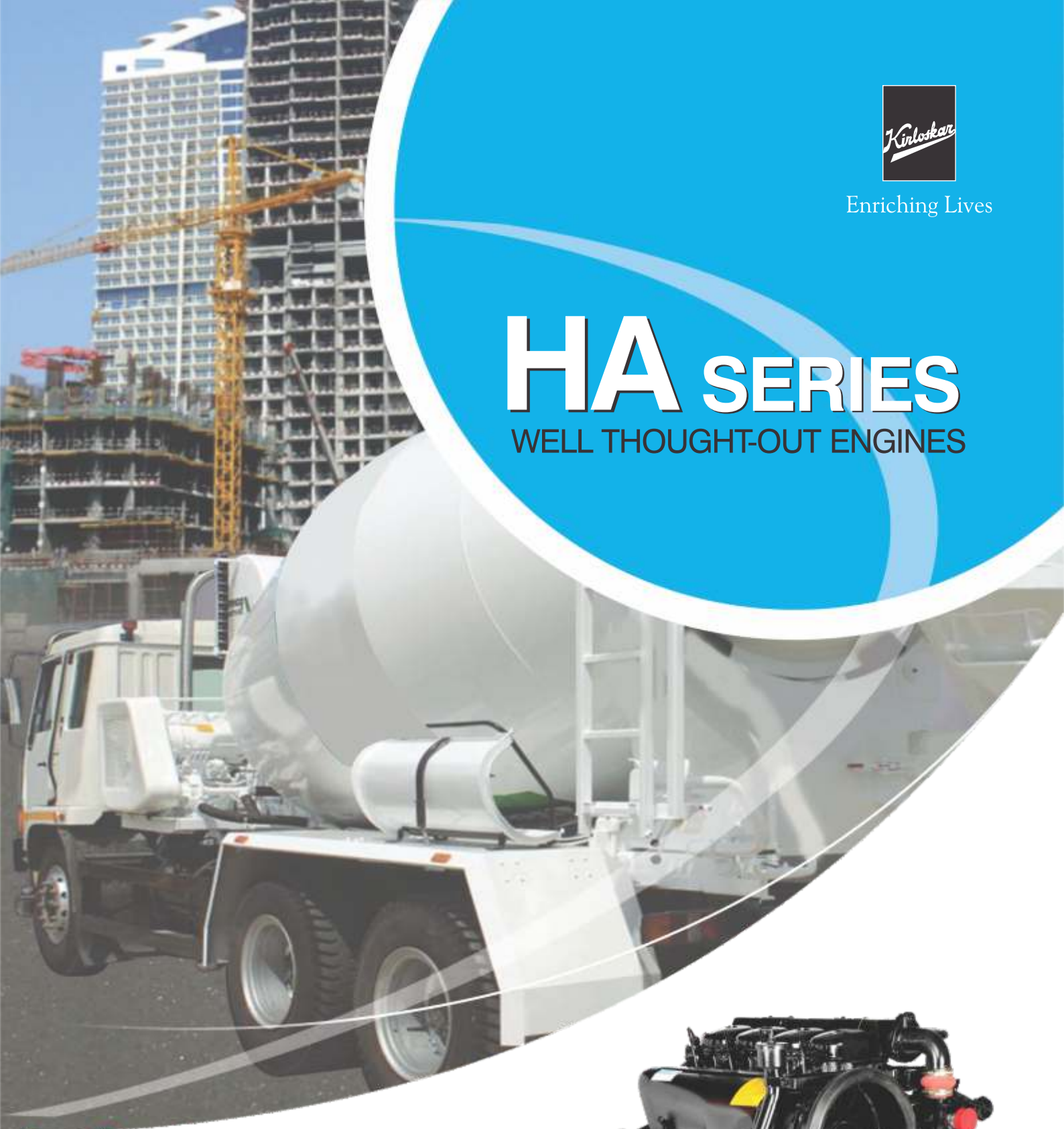

Enriching Lives

HA SERIES

WELL THOUGHT-OUT ENGINES



AIR-COOLED
DIESEL ENGINES



KIRLOSKAR OIL ENGINES LIMITED

Kirloskar Oil Engines Ltd.

A Rich Tradition Of Engineering Excellence



Incorporated in the year 1946, the Kirloskar Group is known for its engineering prowess, penchant for product reliability, business trust and customer orientation. Today, the Kirloskar Group is amongst India's largest multi-product, multi-location diversified engineering conglomerates,

with a turnover exceeding US \$1.6 billion.

Kirloskar Oil Engines Limited (KOEL), incorporated in the year 1946, currently ranks among the leading and largest manufacturers of diesel engines which are manufactured and sold under Kirloskar Brand. Kirloskar engines covers a power envelop span ranging from 4 hp to 800 hp and from 2,400 hp to 11,000 hp, in both air-cooled as well

as liquid cooled, naturally aspirated, turbo and turbo-after-cooled versions.

Annually KOEL manufactures over 2,25,000 engines which are used in over 100 different applications viz. Agriculture, Power Generation, Construction, Material Handling, Earthmoving, Mining, Offshore, Fluid Handling, Agro industrial market segments including Defense and Marine applications. KOEL Exports to over 35 countries worldwide. In India KOEL Engine Sales leads Global Majors such as Perkins, Cummins, Iveco and Caterpillar by a substantial margin.



Air-cooled Diesel Engines

Engineered To Economise

Maximum economy and reliability combined with air cooling are the features of these diesel engines. The power units are produced to meet the high precision and quality standards symbolised by the name Kirloskar.

A strictly modular design ensures component standardisation which solves many spare parts supply problems. Being air-cooled, the HA Series engines work efficiently under different climatic conditions and are easy to maintain.

Salient Features Designed To Outperform

Various applications in industrial, power generation, tractor, mining, earth moving, construction, material and fluid handling, offshore, marine and automotive market segments.

- Piston continuously cooled by built-in oil jet spray for minimum liner piston wear
- Auto-belt tensioning system, resulting in increased belt life
- In-line gear driven BOSCH fuel pump with ease of fuel setting and field servicing
- Lower fuel consumption as compared with other engines in this class (upto 20%)
- Full flow block type lube oil cooler for maintaining optimum lube oil temperature
- Ability to take drive from both engine ends to meet specific application requirement.
- No external lube oil piping for engine lubrication
- Provision for engine-mounted, belt or gear-driven compensatory, gear driven hydraulic pump to meet specific application requirements for compact installation
- All maintenance points like fuel pump, fuel lift pump, lube oil filling, dipstick, fuel and lube oil filters on one side for easy maintenance
- Turbocharged versions available for 4 and 6 cylinder engines.

Standard Features

- Pre and micro fuel filters
- Lube oil cooler
- Fuel lift pump
- Lube oil filter
- Engine stop lever (hand operated)
- Engine supports suitable for rigid mounting
- Torsional vibration damper on crank pulley (for HA694/HA694TC engine only) as applicable
- Automatic belt tension unit.
- Mechanical/Electrical engine shut down system in case of 'V' belt failure

Optional Features

- Engine control panel consisting of start push button, lube oil pressure gauge, ammeters and cutout
- Industrial type silencer suitable for remote mounting
- Spark arrester type exhaust silencer
- Expansion bellow
- Exhaust manifold-cum-silencer for HA294/HA394/HA494/HA694 engine only (replaces separate manifold and exhaust silencer)
- Dry type air cleaner with evacuator valve and restriction indicator (pre-cleaner available on demand)
- Lock nut type speed adjusting unit on fuel pump
- Engine supports
- Hand starting arrangement at gear end on HA294,HA394 AND HA494 only. (This requires extra heavy flywheel which can be accommodated only in SAE-1, Flywheel Housing)
- Holset type flexible coupling with following unfinished bore flanges
- Provision for gear driven hydraulic pump
- Gear driven compressor
- Automatic engine shut-down arrangement in case of low lube oil pressure, high cylinder head temperature, V belt-failure and engine over speed (details on request)
- Hot air outlet ducting and fresh air intake ducting (details on request)
- Engine Model Unfinished bore/ Coupling type
 - HA294/394 22 mm dia
 - HA494/494TC/30 mm dia.
 - 694HA694TC
- Raised oil filling and raised dipstick arrangement
- Special lube oil sumps to suit high inclinations (details on request)
- Flywheel housing (SAE4,3,2 and 1)
- 12V/24V electrical starting system
- Cold starting aid for engine starting below minus 5°C down to minus 20°C (details on request)
- Mud filter and water separator Instruments
 - Low lube oil pressure switch (normally closed type)
 - V belt failure switch
 - High cylinder head temperature switch
 - Engine over speed switch (12V/24V)
 - 12V/24V stop solenoid (in lieu of mechanical shut down)
 - Electrical hour meter and tachometer
 - Lube oil temperature gauge with sensor

Note: Selection depends on application, rpm and torque to be transmitted.



Power Ratings

As per IS:10002/
BS:5514/ DIN
6271/ ISO 3046
ISO STD: Power
(Continuous
Rating)

Engine	rpm	kW	bhp	Torque	
				Nm	Kgm
HA 294	1500	14	19	89	9.1
	1800	16.9	23	90	9.15
	2000	18.4	25	87	8.95
	2300	20.2	27.5	84	8.55
HA 394	1500	23.60	32.00	150	15.30
	1800	28	38.00	148	15.10
	2000	30.2	41.00	144	14.70
	2300	34.60	47.00	143	14.60
HA 494	1500	31.60	43.00	201	20.50
	1800	38.20	52.00	203	20.70
	2300	46.40	66.00	192	19.60
	2500	52.20	70	*	*
HA 494 TC	1500	41.00	56.00	262	26.70
	1800	48.00	65.00	253	25.80
	2000	51.50	70.00	245	25.00
HA 694	1500	47.80	65.00	304	31.00
	1800	57.540	78.00	304	31.00
	2000	62.60	85.00	298	30.40
	2300	69.90	95.00	290	29.60
HA 694 TC	1500	61.00	83.00	387	39.50
	1800	72.00	98.00	380	38.80
	2000	76.00	103.00	365	37.20
	2300	81.00	110.00	340	34.70

Range Of Applications

Kirloskar HA Series engines act as prime movers in a host of critical and demanding applications.

- Water Pumpsets
- Compactors
- Mining Locomotives
- Drill Rigs
- Load-Haul-Dumpers (LHD)
- Sugarcane/ Wood Handlers
- Transit Mixers
- Mining Utility Vehicles



KIRLOSKAR ENGINE POWERING A DRILL RIG



A LOAD-HAUL-DUMPER, POWERED BY A KIRLOSKAR ENGINE

Brief Specifications

Models	HA294	HA394	HA494	HA694	HA494TC	HA694TC
Engine Description	Vertical air cooled, compression ignition, four stroke cycle, naturally aspirated Diesel Engines				Vertical air cooled, compression Ignition, four stroke cycle, Turbocharged Diesel Engines	
Bore x Stroke (mm)	100 x 120					
Displacement (cc)	1884	2826	3786	5652	3768	5652
Compression Ratio	17:1					
Direction of Rotation	Counter-clockwise (looking at flywheel end)					
Speed						
Max Operating (rpm)	2300	2300	2500	2300	2000	2300
Min. operating (rpm)	1500					
Low idling (rpm)	650					
Dry weight without flywheel (kg)	243	300	338	430	338	448
Weight of standard flywheel for industrial application (kg)	41	41	39	39	39	39

Note:

For choosing an engine that best suits your requirement, please consult with KOEL R&D

Overall Dimensions & Installation Drawings

HA294/ HA394/
HA494/ HA694
engines

Engine Model	A	B	C*	D*	X	X1
HA294	678	704	872	301	342	455
HA394	808	704	868	297	272	585
HA494	938	704	868	297	602	715
HA694	1277	704	922	300	869	982
HA494TC	938	704	868	297	602	715
HA694TC	1145	760	878	300	869	982

*All dimensions are in mm, these dimensions may vary from alternations depending on applications.

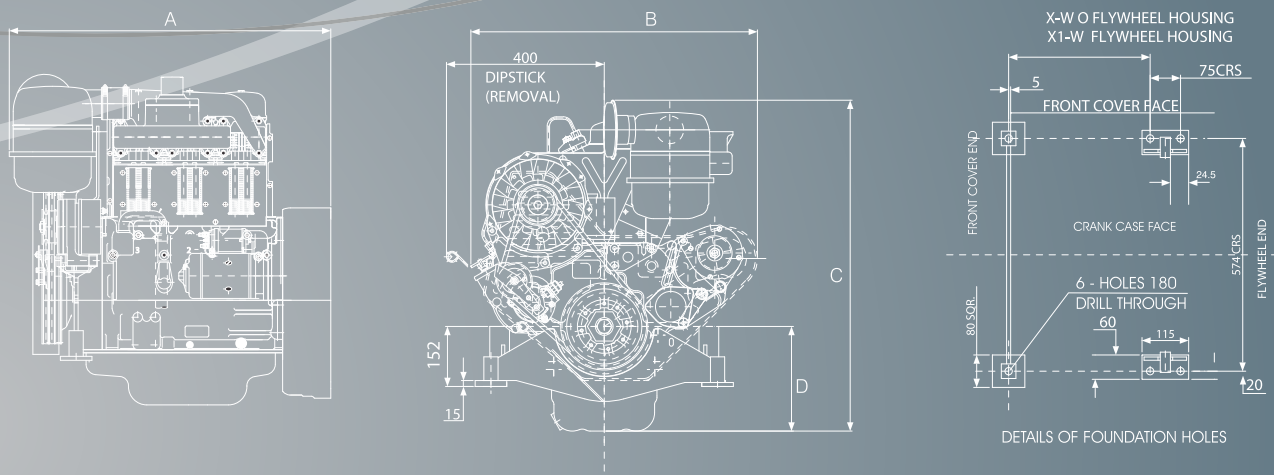

Kirloskar global presence



- Angola ■ Benin ■ Cambodia ■ Egypt ■ El Salvador ■ Guatemala ■ Guinea ■ Honduras ■ Iran ■ Iraq ■ Jordan
- Kenya ■ Lao PDR ■ Lebanon ■ Malawi ■ Mauritius ■ Morocco ■ Myanmar ■ Namibia ■ Nepal ■ Nigeria ■ Oman
- Panama ■ Saudi Arabia ■ South Africa ■ Sri Lanka ■ Syria ■ Tanzania ■ UAE ■ Uganda ■ USA (Florida) ■ Zambia

Kirloskar JLT

P. O. Box 37745, Unit No. 504, Jumeirah Business Centre 5, Jumeirah
Lake Towers, Dubai, United Arab Emirates
Tel.: +971 4 443 8591, Fax: +971 4 441 4532, E-mail: kmef-
admin@kirloskar.ae

Kirloskar Kenya Ltd.

P. O. Box 60061 Off Dunga Road, Nairobi, Kenya. Tel.: +254 20 653 6632,
Fax: +254 20 653 3390,
Email: rspatil@kirloskar.co.ke

Joburg Industrial Trading S.A. (Pty) Ltd.

Trade Name: KIRSONS

Unit B1, The Stables Business Park, Cnr of third avenue & second road,
Limbro Park, Modderfontein, Johannesburg,
Tel.: +27(0) 11 553 6900/ 6903. Email: kirsons@kirloskar.co.za



Enriching Lives

KIRLOSKAR OIL ENGINES LIMITED

Laxmanrao Kirloskar Road, Khadki, Pune 411 003, India

Tel.: +91(20) 2581 5341, 2581 0341

Fax: +91(20) 2581 3208, 2581 0209

Website: www.koel.co.in

Stamp of
Authorised
Representative